

**READ THESE INSTRUCTIONS BEFORE YOU BEGIN INSTALLATION****PRODUCT APPLICATION**

The A/TT-RSO is a temperature transmitter product family intended for room applications. Optional features, if selected, provide useful features often desired in room applications, including setpoint and override outputs. Both the temperature transmitter and the setpoint transmitter functions support 4-20mA, 1VDC to 5VDC, and 2VDC to 10VDC output options. The setpoint function also supports resistance output options, with or without an offset resistance. The override function provides a normally open dry-contact switch output for occupancy indication.

This instruction covers the following A/TT-RSO family products: A/TT-R, A/TT-RS, A/TT-RSO and A/TT-RO.

CAUTION—ELECTRICAL HAZZARD: Can cause electrical shock or equipment damage. Be sure to make all connections with the power source turned off.

CAUTION—Do not mount product in refrigerated areas, and do not allow condensation to form on product.

INSTALLATION INSTRUCTIONS

Mounting:

Install the A/TT-RSO in a room location approximately 5 feet (1.5m) above the floor, preferably on an interior wall in an area with good air circulation and average temperature. **Do not mount** in areas with drafts or dead spots, in areas affected by hot or cold air ducts, or in areas with direct sunlight or other radiant heat sources.

Remove the cover from the base; if needed turn the (2) 1/16" Allen Screws located at the bottom of the base clockwise in order to remove the cover from the base. Pull wires through the wire access area in the base located near the terminal blocks. Mount the base to the wall, using the (2) 6/32" x 1" screws provided. Replace the cover and tighten down, using the (2) 1/16" Allen screws located on the bottom of the base.

Power Source:

8.5VDC to 32VDC (AC voltage is not supported).

Temperature transmitter function: 25mA maximum.

Setpoint transmitter function: 25mA maximum if current or voltage output is selected.

Notes:

1. If the A/TT-RSO is selected with both the temperature and the setpoint transmitter features, 50mA is required from a single power source.
2. The A/TT-RSO temperature transmitter function and setpoint transmitter function can be operated with two power sources to allow for separate 4-20mA current loops.
3. If the A/TT-RSO is selected with the resistance setpoint feature, the setpoint resistance supports a maximum of 0.25 Watt power dissipation capability.

Wiring: (All wiring must comply with applicable local electrical codes and ordinances.)

The use of 18 to 22 AWG shielded cable is recommended for all wiring applications. Terminate the shield at the controller-end.

A minimum of 2 and a maximum of 7 wires are required to operate the A/TT-RSO, depending on the features selected. The A/TT-RSO has terminal blocks installed to support the selected features. Loosen the appropriate screw terminals. Insert the wires into the terminal block, and then re-tighten the screws. Place the cover back onto the base and turn the setscrews counter-clockwise to hold the cover.

Wiring Diagrams:

Typical 2-wire 4-20mA Current Loop Transmitter Connections:

Figure 1: A/TT-R (Current Output)

Temperature: 4-20mA

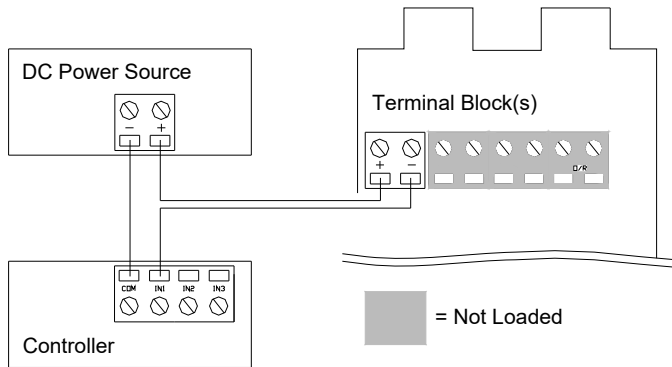

Figure 2: A/TT-RS (Current Output)

Temperature: 4-20mA
Setpoint: 4-20mA

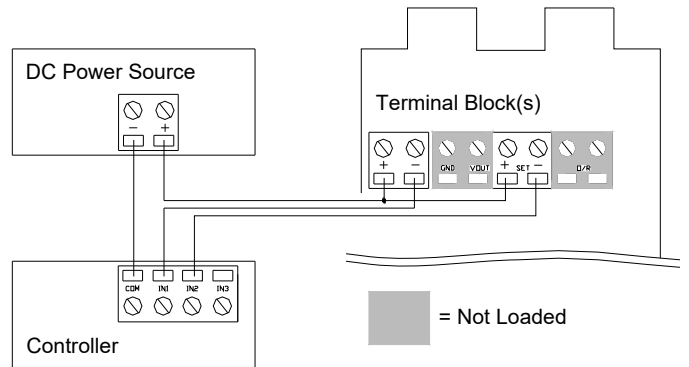

Figure 3: A/TT-RSO (Current Output)

Temperature: 4-20mA
Setpoint: 4-20mA
Normally Open Dry-Contact Override

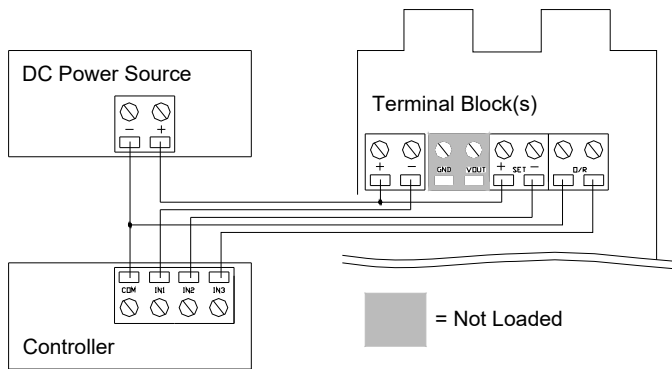
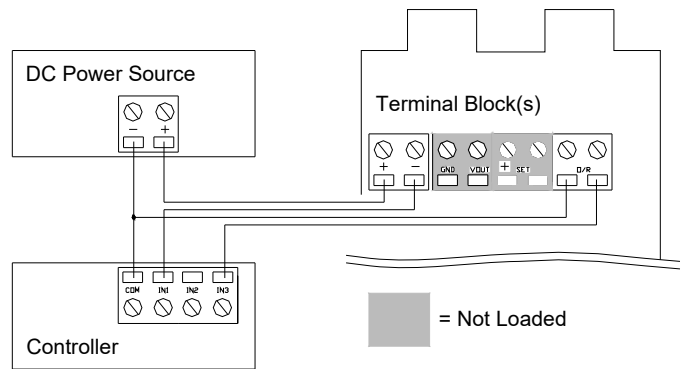

Figure 4: A/TT-RO (Current Output)

Temperature: 4-20mA
Normally Open Dry-Contact Override



Wiring Diagrams:

Typical Voltage Transmitter Output Connections:

Figure 5: A/TT-R (Voltage Output)

Temperature: 1VDC to 5VDC or 2VDC to 10VDC

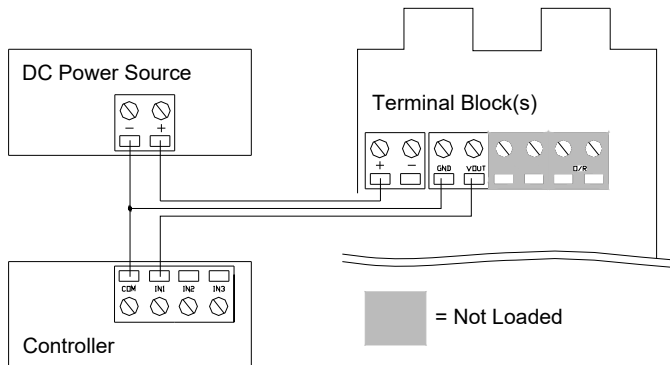

Figure 6: A/TT-RS (Voltage Output)

Temperature: 1VDC to 5VDC or 2VDC to 10VDC
 Setpoint: 1VDC to 5VDC when R (resistor) is 249 ohms
 Setpoint: 2VDC to 10VDC when R (resistor) is 499 ohms

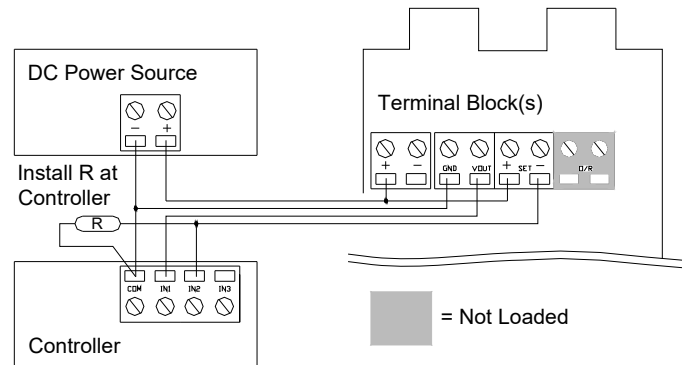

Figure 7: A/TT-RSO (Voltage Output)

Temperature: 1VDC to 5VDC or 2VDC to 10VDC
 Setpoint: 1VDC to 5VDC when R (resistor) is 249 ohms
 Setpoint: 2VDC to 10VDC when R (resistor) is 499 ohms
 Normally Open Dry-Contact Override

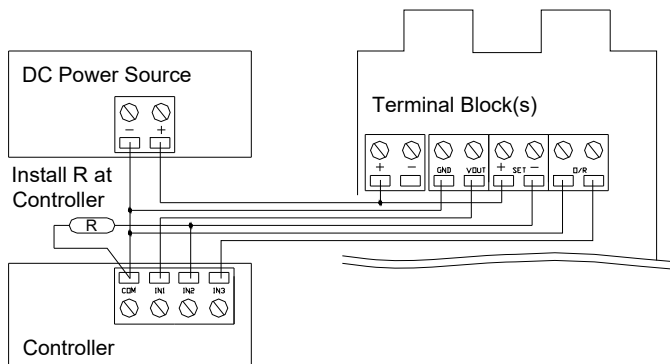
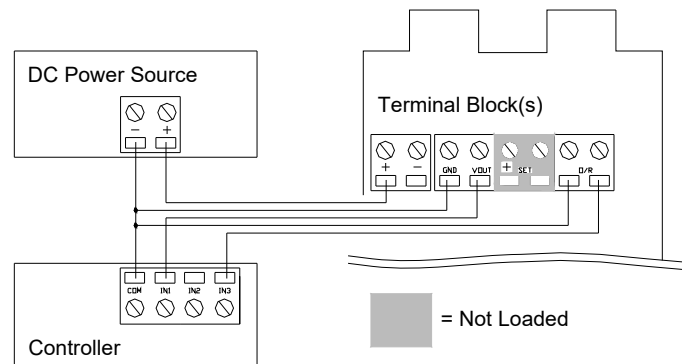

Figure 8: A/TT-RO (Voltage Output)

Temperature: 1VDC to 5VDC or 2VDC to 10VDC
 Normally Open Dry-Contact Override



OPERATION INSTRUCTIONS

General:

After mounting and wiring the A/TT-RSO family product, apply power to the system.

Temperature:

Observe the temperature signal at the end-device. If no temperature signal is observed, be sure the two sensor shunts are installed on the A/TT-RSO circuit board (shunts located in the lower right corner).

Setpoint: (If selected)

Observe the setpoint signal at the end-device. Change the setpoint by moving the slide lever located at the bottom of the enclosure.

Override: (If selected)

Observe the override signal at the end-device when the override pushbutton, located on the right side of the enclosure, is pressed.

PRODUCT SPECIFICATIONS

Supply voltage:	Terminal voltage: 8.5VDC to 32VDC 249 ohm load resistance: 13.5VDC to 32VDC 499 ohm load resistance: 18.5VDC to 32VDC Maximum load resistance: (Supply voltage-8.5)/0.02 Maximum terminal voltage: 32VDC
Output current: (Current output models.)	Nominal: 4mA to 20mA Maximum: 25mA Minimum: 3mA
Output voltage: (Voltage output models.)	Nominal: 2VDC to 10VDC Maximum: 12.5VDC Minimum: 1.5VDC
Calibration accuracy: (Includes linearity.)	±0.2% of full scale
Temperature drift:	±0.04% of full scale output
Voltage drift:	±0.001% of full scale output (Output change per volt change across terminals.)
Warm-up drift:	±0.1% of full scale output (After 10 minutes.)
Operating temperature:	32°F to 122°F (0°C to 50°C)
Operating humidity:	0% to 90% (Operating environment must be NON-CONDENSING.)